

**Built-in external event detection.**  
**SERIAL INTERFACE REAL TIME CLOCK MODULE**



**RX-4575 LC**

- Built in frequency adjusted 32.768 kHz crystal unit.
- Interface Type : Serial interface in 3 lines form.
- Operating voltage range : 1.6 V ~ 5.5 V
- Wide timekeeper voltage range : 1.3 V ~ 5.5 V
- Low backup current : 0.35  $\mu$ A / 3 V ( Typ. )
- External event detection. : Chattering free input port \* 2.  
 (The various functions include full calendar, alarm, timer.)



Actual size



**Block diagram**

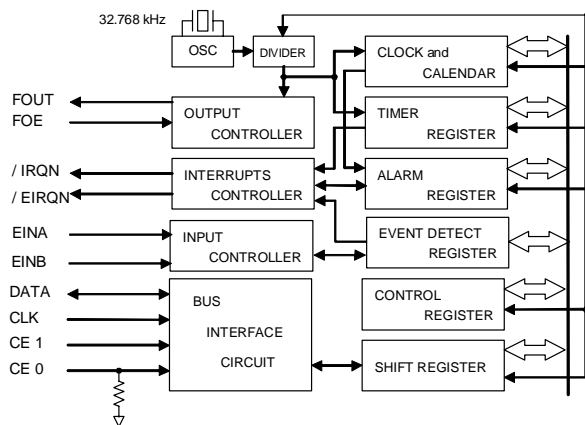

**Overview**

- **Event detection.**
  - Selectable Hi detection or Lo detection.
  - Recognition of detection is available both the hardware interrupt and the monitor via software.
  - Automatic interrupt release mode is available.
  - The all 'OR' interrupt output is possible via alarm, timer and event detection.
- **Performance of event input terminal.**
  - As for the chattering filter, following are prepared for. ( 8ms, 31ms, 62ms, 125ms )
  - Built-in resistor connect and release is possible via software. Selectable pull-up or pull-down.
- **Timer function**
  - Built in 12 Bit counter.
  - Timing period are 1 min, 1 sec, 64Hz, 4096Hz.
- **Alarm function**
  - Alarm setting is possible by combination of a day, hours, and minutes.

**Pin Function**

Signal Name	Input / Output	Functions
EINA EINB	Input	External event input pin.
CE 0 CE 1	Input	Interface is possible when both CE0 and CE1 is high level.
CLK	Input	Serial Clock input pin.
DATA	Bidirectional	Data input and output pin.
FOUT	Output	32.768 kHz clock output pin ( C-MOS ) . Output is Hi-Z when OFF.
FOE	Input	32kHz is output when input is Hi, 32kHz is OFF when input is Lo.
/ EIRQ	Output	Interrupt output pin. ( N-ch open drain )
/ IRQ	Output	Interrupt output pin. ( N-ch open drain )
VDD	—	Connected to a positive power supply.
GND	—	Connected to a ground.

**Terminal connection / External dimensions (Unit:mm)**

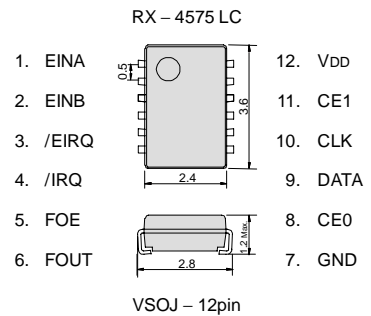

**Specifications (characteristics)**

\* Refer to application

■ Recommended Operating conditions

Item	Symbol	Condition	Min.	Typ.	Max.	Unit
Power voltage	VDD	—	1.6	3.0	5.5	V
Clock voltage	VCLK	—	1.3	3.0	5.5	V
Operating Temperature	TOPR	—	-40	+25	+85	°C

■ Frequency characteristics

Item	Symbol	Condition	Rating	Unit
Frequency tolerance	$\Delta f / f$	Ta = +25 °C VDD = 3.0 V	5 ± 23 *	$\times 10^{-6}$
Oscillation Start-up time	tSTA	Ta = +25 °C VDD = 1.6 V	1 Max.	s
		Ta = -40 °C ~ +85 °C VDD = 1.6 V	3 Max.	s

\*Equivalent to 1 minute of monthly deviation

■ DC characteristics

Ta = -40 °C ~ +85 °C

Item	Symbol	Condition	Min.	Typ.	Max.	Unit
Current Consumption	IBK	CE0, CE1 = GND / IRQ, / EIRQ = OFF FOUT : output OFF Event detection OFF	VDD = 5 V	0.45	0.9	$\mu$ A
		VDD = 3 V	0.35	0.7		
Current Consumption	I32k	CE0, CE1 = GND / IRQ, / EIRQ = OFF FOUT ; CL = 30 pF 32.768 kHz output ON	VDD = 5 V	8.0	20.0	$\mu$ A
		VDD = 3 V	5.0	12.0		

# “3D STRATEGY” EPSON TOYOCOM

In order to meet customer needs in a rapidly advancing digital, broadband and ubiquitous society, we are committed to offering products that are one step ahead of the market and a rank above the rest in quality. To achieve our goals, we follow a “3D (three device) strategy” designed to drive both horizontal and vertical growth. We will to grow our three device categories of “Timing Devices”, “Sensing Devices” and “Optical Devices”, and expand vertical growth through a combination of products from these categories.

Quartz devices have become crucial in the network environment where products are increasingly intended for broadband, ubiquitous applications and where various types of terminals can transfer information almost immediately via LAN and WAN on a global scale. Epson Toyocom Corporation addresses every single aspect within a network environment. The new corporation offers “Digital Convergence” solutions to problems arising with products for consumer use, such as, core network systems and automotive systems.

## PROMOTION OF ENVIRONMENTAL MANAGEMENT SYSTEM CONFORMING TO INTERNATIONAL STANDARDS

At Epson Toyocom, all environmental initiatives operate under the Plan-Do-Check-Action(PDCA) cycle designed to achieve continuous improvements. The environmental management system (EMS) operates under the ISO 14001 environmental management standard. All of our major manufacturing and non-manufacturing sites, in Japan and overseas, completed the acquisition of ISO 14001 certification. In the future, new group companies will be expected to acquire the certification around the third year of operations.

ISO 14000 is an international standard for environmental management that was established by the International Standards Organization in 1996 against the background of growing concern regarding global warming, destruction of the ozone layer, and global deforestation.

## WORKING FOR HIGH QUALITY

Epson Toyocom quickly began working to acquire company-wide ISO 9000 series certification, and has acquired ISO 9001 or ISO 9002 certification for all targeted products manufactured in Japanese and overseas plants.

Epson Toyocom has acquired QS-9000 certification, which is of a higher level. Also, TS 16949 certification, which is also of a higher level, has been acquired.

QS-9000 is an enhanced standard for quality assurance systems formulated by leading U.S. automobile manufacturers based on the international ISO 9000 series.

ISO/TS 16949 is a global standard based on QS-9000, a severe standard corresponding to the requirements from the automobile industry.

## Notice

- This material is subject to change without notice.
- Any part of this material may not be reproduced or duplicated in any form or any means without the written permission of Epson Toyocom.
- The information, applied circuitry, programming, usage, etc., written in this material is intended for reference only. Epson Toyocom does not assume any liability for the occurrence of infringing on any patent or copyright of a third party. This material does not authorize the licensing on for any patent or intellectual copyrights.
- Any product described in this material may contain technology or the subject relating to strategic products under the control of the Foreign Exchange and Foreign Trade Law of Japan and may require an export license from the Ministry of International Trade and Industry or other approval from another government agency.
- These products are intended for general use in electronic equipment. When using them in specific applications that require extremely high reliability, such as the applications stated below, you must obtain permission from Epson Toyocom in advance.
  - / Space equipment (artificial satellites, rockets, etc.) / Transportation vehicles and related (automobiles, aircraft, trains, vessels, etc.)
  - / Medical instruments to sustain life / Submarine transmitters / Power stations and related / Fire work equipment and security equipment
  - / traffic control equipment / and others requiring equivalent reliability.
- In this new crystal master for Epson Toyocom, product codes and markings will remain as previously identified prior to the merger. Due to the on-going strategy of gradual unification of part numbers, please review product codes and markings, as they will change during the course of the coming months. We apologize for the inconvenience, but we will eventually have a unified part numbering system for Epson Toyocom that will be user friendly.